

CCIB Intermodal Seminar

Doubletree Hotel , Alsip Il.

September 24, 2009

Loadshifts

and

Proper Blocking and Bracing Techniques

A Photo Review

Reported as a LOADSHIFT

Trailer Mechanical personnel are often the first investigative responders at many facilities

Is it actually a loadshift account improper loading or missing / failed blocking on the part of shipper?

Nature of product ?

Equipment fatigue / failure?

Weight distribution/ load pattern issue ?

Reported to stop storage charges ?



Loadshift / leaner

What to check on parked container :

*Landing gear legs same length –not making lean

*Have hostler hook and lift nose – doe it lean ?

Have hostler make a slow left and right turn.

*Carefully open door, expecting lading to fall out

*Take a photo showing entire doorway , looking down top of load to nose, down both walls showing voids and any blocking

* Record seals removed and applied for claim dept purposes



Leaner –load of window air conditioners and LCD tv's are loaded on rear with air conditioners 4 to 5 times heavier loaded on one side.

Shipper needs to plan loading based on different product weight – loading container evenly lengthwise and crosswise

**Equipment Damage caused by fatigue, handling
or product loading, weight or shifting**



A collapsing gantry crane - not a loadshift issue-



Large tractor axle breaking through container floor account concentrated weight on floor footprint in excess of 2500#/ foot. Floor should have been reinforced with heavy lengthwise bearing pieces.



Floor adjacent tunnel area bowing downward account floor is overloaded . Product should have been loaded single file in-line with lateral and lengthwise blocking.



Twisted crossmembers from floor overloads

Floor broken out by forklift exerting more than 2500# per foot on flooring



TARE WT 841



NOT LOADSHIFT DAMAGE

Packer arms positioned off lift pads causing side sheets to buckle with unsupported weight of tandems and load .

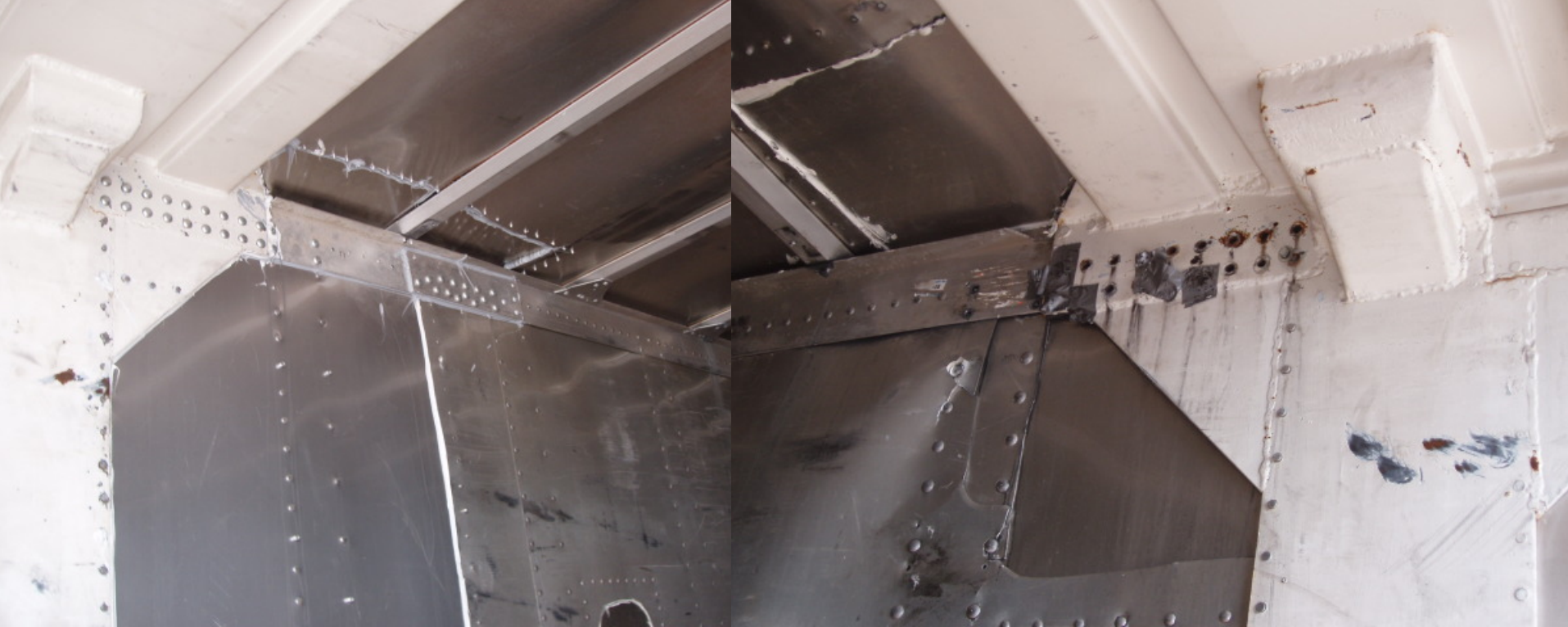

Reported as a loadshift - one top rail previously over-plated and opposite rail continued to deteriorate , bolts missing- popping sidesheets .



Taped sidesheet seam reported as a loadshift – this was previous damage .

Load is not shifted- loaded under an insulating blanket for temperature control. Airbag is overextended in large void.

Product is not high enough to cause pictured damage



Container top /bottom rail failing on a spine car – this is not caused by pictured liquor load . Cause -fatigued container or top rail damaged by ramp lift equipment.





Handstack load falling to floor account no blocking – this is not a loadshift that needs to be stopped for adjustment unless, it is leaning to one side account different weight products stacked unevenly side to side. This would be determined by having hostler lift nose and make slow turns .



Improperly applied blocking which will damage doors or pop them open. This blocking concentrates weight on center of doors. This can bend doors and locking bars.

Doors can not be used to restrain a load unless it is under 40,000 lbs , multiple cartons i.e. clothes etc and cover 65% of the door surface with no lengthwise voids .

Loadshift of tractor parts not blocked and braced concentrating weight on bottom of doors – bending locking bars.

Load should have floor blocking, bullboards in door frame or tygard barriers.





2x4 bullboard in logistic track – blocking one layer

Doors can not be used restrain this load. Steel pieces should be banded lengthwise to pallets with floor blocking or bullboards in doorframe pocket

Improper Airbag application can result in equipment damage and loadshifts laterally or lengthwise

Airbags properly inflated in a 4-12” void, not extending above or beyond product stack, is acceptable as lengthwise securement. Inflated airbag should be taut –hard to the touch.



Airbags over inflated and extending above top of load. Right side of load is flush to wall. Airbags made left side semi-rigid, not flexing as designed to. Placing airbags at walls and not on centerline often bulges walls. Loads of tires, fiberglass insulation, long rolls of carpeting or padding will also bulge sidewalls.

Airbags should be filling a 4-12" void after inflation and should not extend above or beyond stack being braced.



Lengthwise Weight Distribution

Ramp reported container handled like a loadshift with nose high behind a hostler . Load is not shifted – airbags are too tall extending above product. Tall units are loaded in an offset 2-1-2 pattern – starting 9 ft from the doors. Minimum weight above rear tandems , with nose lifted it will lean . Load was released for crosstown.

Load locks are not approved for rail shipments – they fall out of place with vibration. Application on top of cardboard further reduces their pressure against sidewall.



Airbags can not be folded, as shown, airbag is ineffective as lengthwise securement . This is same load as previous slide and may shift lengthwise.





Airbag too large – it should not extend above or beyond product stack being braced. Bag will pop out of place.

Drums need to be unitized to pallets with strapping encircling horizontally and in two directions vertically. White nylon filament barrier is Tygard . There should be total of four barriers –two at doors and two midway in load – taped up to prevent drooping
Note the wet floor – roof leak.



Sleds (LRP) of metal product –No B&B- shifted. Sleds are designed to distribute weight lengthwise in container . Must be blocked in place with 2x 6 guiderails and 18” 2x6 cleats to maintain position lengthwise or crosswise





Masticated rubber matting, as lengthwise securement under rolls, is usually required to be full length under rolls - not sized to single roll diameter

Rear rolls or rolls loaded in two group require a unitizing straps to prevent rocking off mats as shown in picture



Rolls loaded on a full length rubber mat have shifted account no unitizing strap encircling the four rolls as a group.



Skidded flatstock paper shifted to left side by harmonic vibration account no blocking and bracing. Load should have 2x4 guide rails with 18" 2x4 back-up cleats on floor for lateral blocking and lengthwise blocking. If loaded two units wide , full length rubber mats may be OK'd by carrier



Large forklift is a floor overload besides being shifted account improper blocking and bracing . Minimum blocking is laminated 2x6's to prevent lengthwise and crosswise movement after reinforcing floor to distribute weight .



Failure to block load in laterally (wall to wall) and lengthwise weight distribution. While load is blocked in lengthwise, shipper failed to apply 2x4 guiderail and/or 18" 2x4 cleats to prevent lateral movement from harmonic vibration. Load starts in front of rear stacking posts, it should be nose heavy for some lift equipment.

Palletized ingots – no B&B- load has shifted. Lightweight pallets collapsed with harmonic vibration. Marks on floor show original position. Ingots should be banded in both directions on heavy skids with 3x3 or larger runners. Lengthwise 2x4 guiderails with back-up cleats for lateral movement . Laminated 2x4's with back-up cleats for lengthwise blocking





NOT ACCEPTABLE – Potential lengthwise shift / nose heavy
Cable and turnbuckle are affixed lading anchors rated for only 4,000lbs - should use a wood gate or tygard to secure second layer. Airbags can not be used account crosswise void is not 4-12” required for inflated airbag

Offset loading on floor right-left -right leaving crosswise void is acceptable if there is stack to stack contact and lengthwise blocking. Partial second layer not secured or blocked in place
Acceptable lengthwise securement would be airbags ,tygard, floor blocking. Drop fillers for crosswise void





Loadshifted bulk tanks of a corrosive loaded two wide in an offset pattern (left -right-left)– shifted to left side. Only restraint is a single nylon strap secured to logistics track. Load should be floor blocked with 2x4's to maintain longitudinal and lateral position.



Two 16,000# manlifts secured to lading anchors rated for only 4000#



Strapping can not be run at 90 degrees, wall to wall, without being secured behind the face of the load to distribute pulling forces. This track is pulling off wall.

Nose heavy – 33,000# load in the front 34ft of 53ft
box- load stacked high – no blocking





Units of lumber – leaner account more lumber loaded on left side and no lateral filler to prevent movement to one side .



Lumber load -no lengthwise /crosswise blocking –shifted to right side . Load is also nose heavy

Single unit at nose can bow out / separate nose sheet





Top spools are tied together crosswise with a 2x4 but, lower level spools are free to move about, dropping upper layer . Unitization , securing stack to pallet can be accomplished with strapping in two directions or heavy stretch wrap

Poorly designed top heavy rack (5 times taller than it is wide) has tipped and is now chafing through side sheet .



Ingots shifted -no B&B- harmonic vibration caused movement. Need wood floor blocking – 2x4 guiderails with 18” backup cleats. Must distribute weight evenly lengthwise and crosswise .
No more than 25,000# in any 10 feet



Totes of chili mash – no B&B- Large boxes (gaylords) not strong enough or secured to pallets. Load shifted and boxes vibrated /tipped off pallets. Need wood floor blocking and heavier gaylords totes unitized /banded to pallets



Haz Mat load – Potential leaker- different packaging requires rigid buffer (1/2” plywood/OSB or equivalent) to prevent chafing caused leakage



Uneven loading stacked to roof at nose – container will readily lean behind a turning hostler . Airbag is over-inflated extending above product stack



ACCEPTABLE BLOCKING AND BRACING METHODS

AAR Tested and Approved Methods and Materials
(as found in AAR Intermodal Loading Guide)

Wood Blocking - minimum 18" 2x4

Proper nail application

Bullboards

Airbags

Tygar

Gates on floor or E-trac

Masticated rubber matting as tested

Logistick

Drop fillers

Unitization to Pallets

Double Laminated Floor Blocking

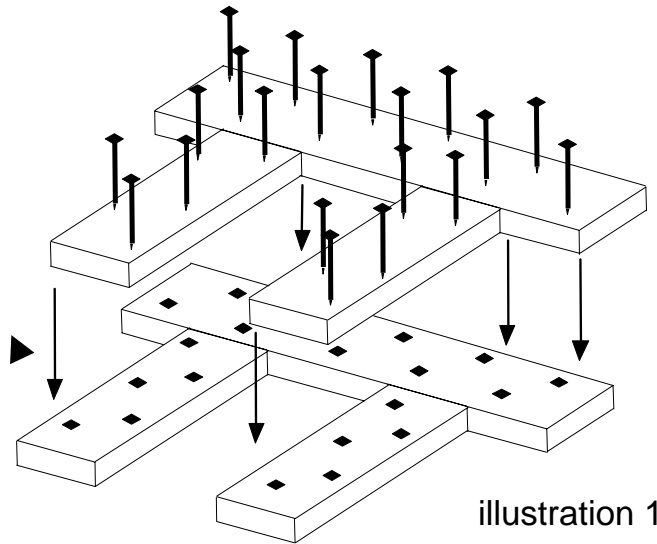
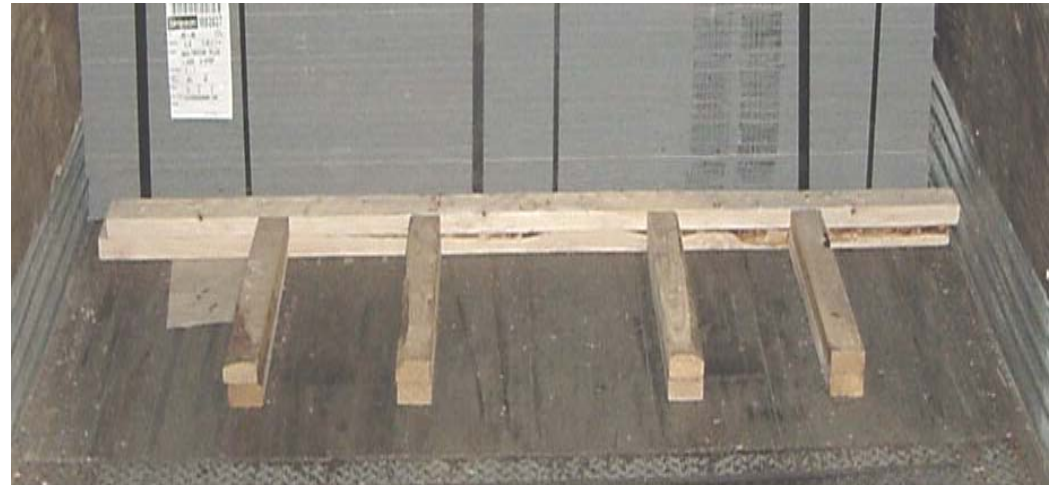

illustration 1



FLOOR BLOCKING SHOULD BE CONSTRUCTED OF DOUBLE LAMINATED 2x6 OR 2x4 LUMBER WITH BACK UP CLEATS AT LEAST 18 INCHES LONG. 16d NAILS SHOULD BE STAGGERED AND SPACED APPROXIMATELY 4 TO 5 INCHES APART TO PREVENT LIFTING WITH VIBRATION.

Acceptable coil load
in two groups 2x6
blocking – guiderails
parallel skids at
lateral cleats .





2x6 laminated floor blocking - should have two more back-up cleats but is acceptable as pictured . Load is tight wall to wall

Bull-Board Installation

Bull Board

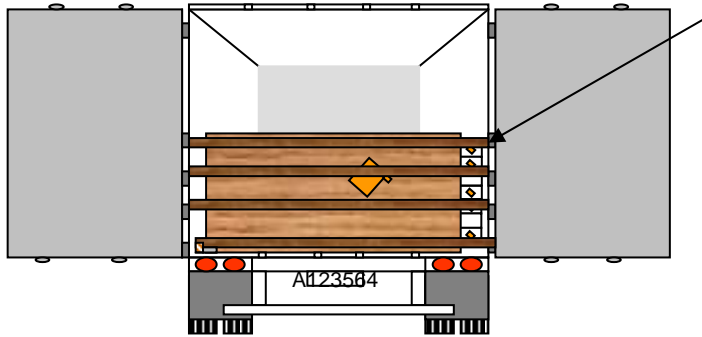

INSPECTOR VIEW
SLOTS (Center or side)

Note: VIEW SLOTS
SHOULD BE LARGE
ENOUGH TO VIEW,
PACKAGING,
METHOD OF
LOADING, BUT NOT
LARGE ENOUGH TO
ALLOW PACKAGE TO
FALL THROUGH
VIEWING VOID.

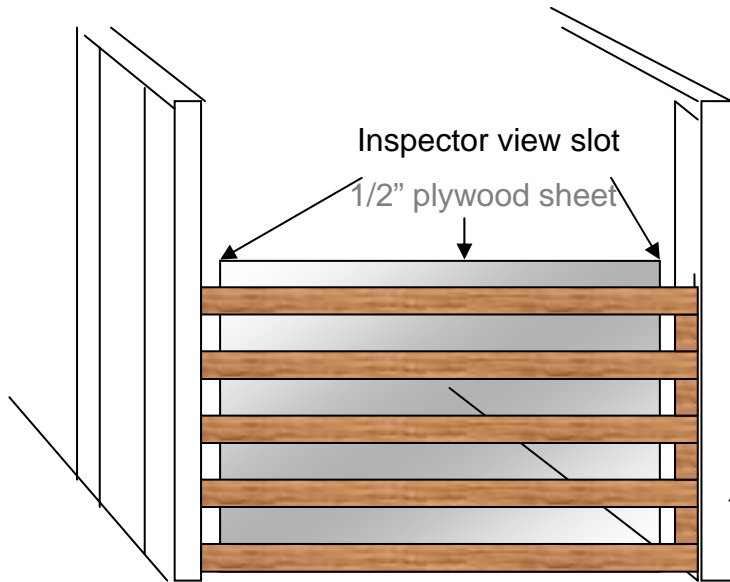
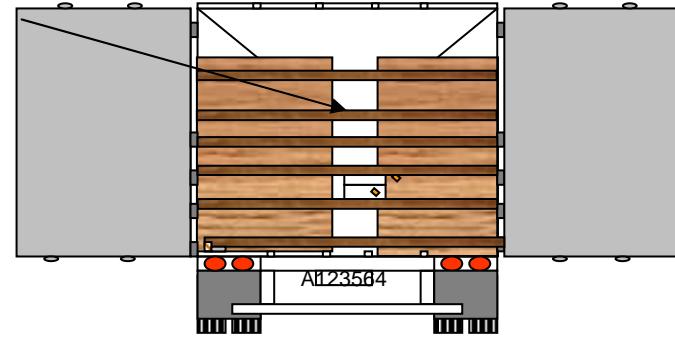

Expanded view

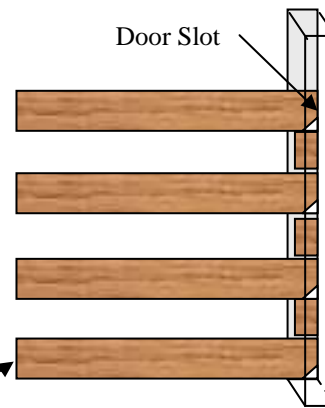

Installation of Bull Boards

- 1) measure length from inside door slot to inside door slot
- 2) Cut 2x6 1/16 inch Longer then length measure in #1 above
- 3) Cut bevel into bottom corner of 2x6 for installation into the door slot.

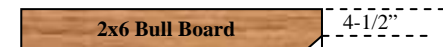

- 4) Hammer 2x6 into door slot
- 5) Insert vertical spacer to maintain alignment.
- 6) repeat steps 1 thru 5
- 7) solid board bull boards consist of all lateral boards and no vertical spacers.



Properly constructed doorway filler with
horizontal 2x6 bullboards in doorway frame
Placard (2790) improperly positioned as a square



Bullboards in doorframe with tri-ply corrugated bulkhead to restrain bulk grain load. Bulk loads must be evenly distributed lengthwise and crosswise in container for safe handling by hostlers or lift equipment.

Proper Airbag Application

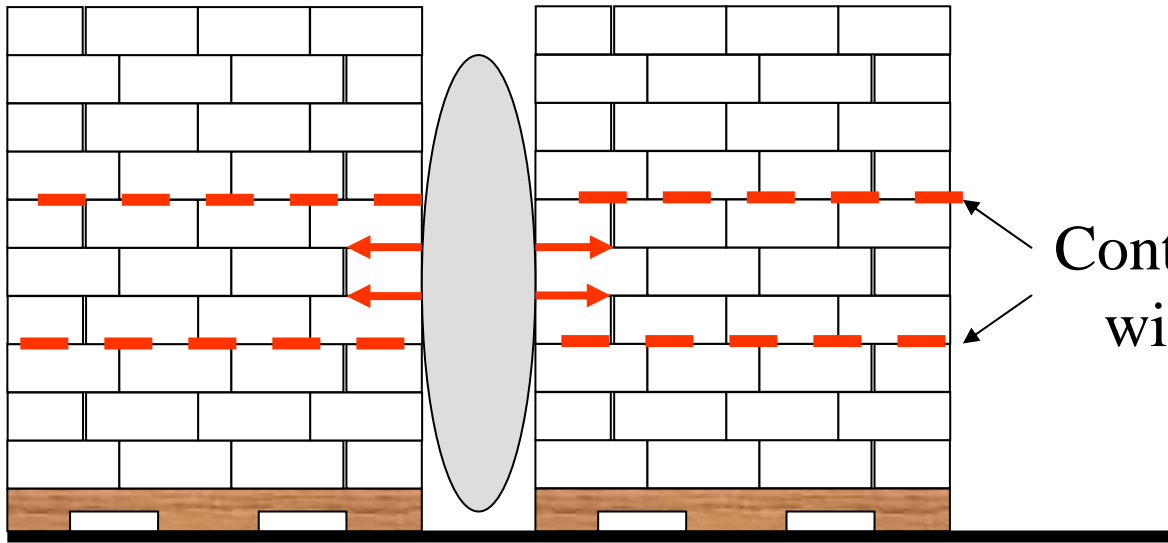

Contact area of the air bag
without buffer material

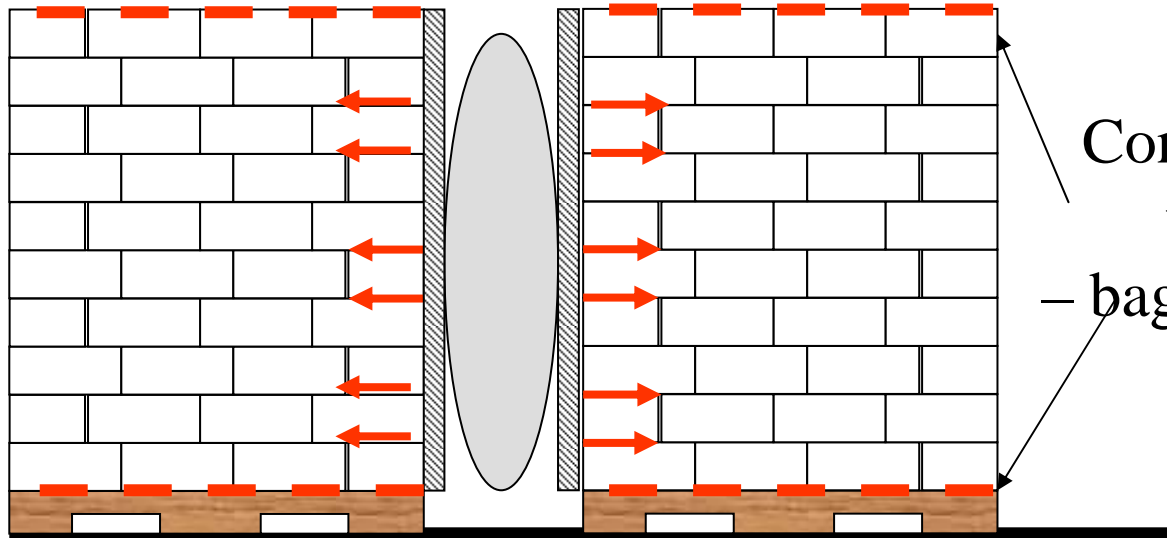

Contact area of the air bag
with buffer material
– bag actually filling a void of
4-12”

AirBag Placement and Usage Guidelines for Securing InterModal PalletLoads

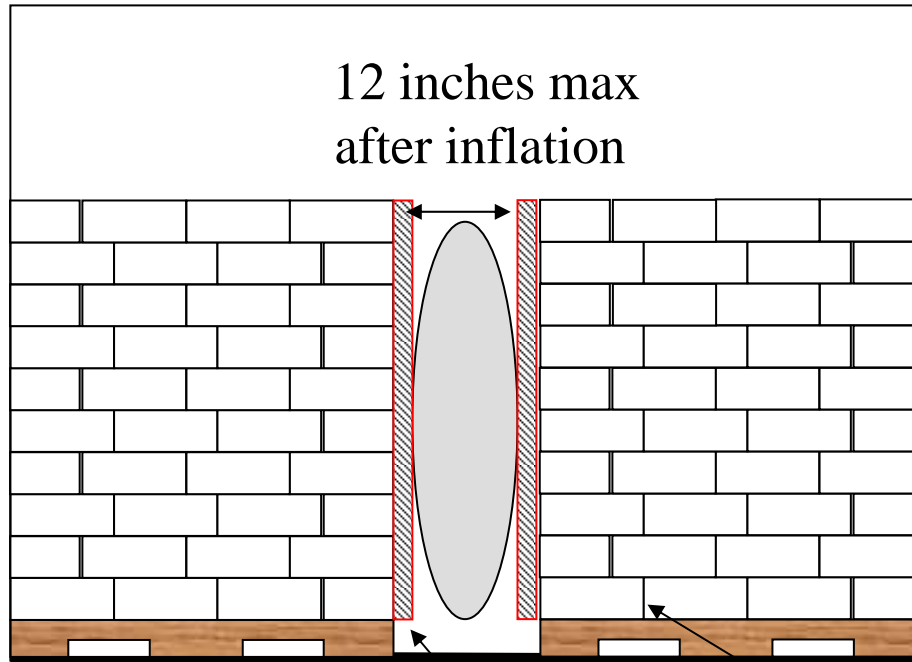
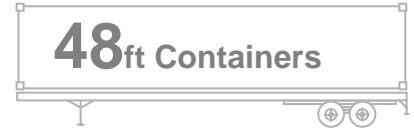

12 inches max
after inflation

Air Bag (typical)

Specifications : 48" x 96" x 4 ply D.I.D. air bag with 90 lb. extensible paper cover and 5 mil interior bladder. Inflated with gauge to mfg. specs.

Buffer Material Around Air Bag (typical)

Specifications : 48" x 96" x 5" ,
Kraft paper faced with 5.5" interior cell ,
1,100 lb. crush resistance.
Approx. holding power= 10,000lbs. / bag



Union Pacific Damage Prevention
File: Welch's #3

Date: 01/08/04 By: WLR



Proper airbag application in a 4-12" void with 1" diamond cor panels between bag and product .
Top of bag is almost level with top of product

TY- Gard Installation

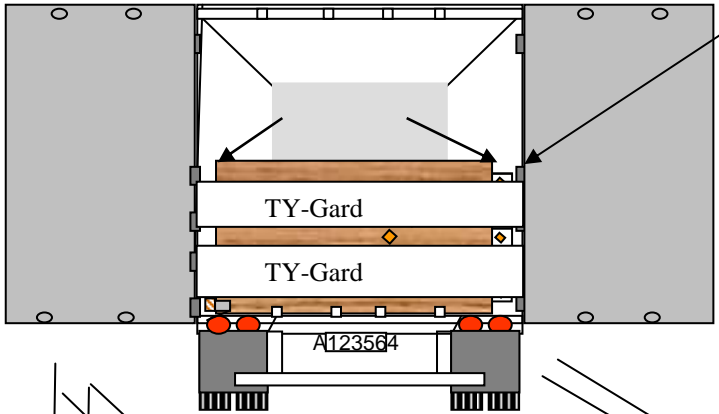

INSPECTOR VIEW SLOTS (Center or side)

Note: VIEW SLOTS SHOULD BE LARGE ENOUGH TO VIEW, PACKAGING, METHOD OF LOADING, BUT NOT LARGE ENOUGH TO ALLOW PACKAGE TO FALL THROUGH VIEWING VOID.

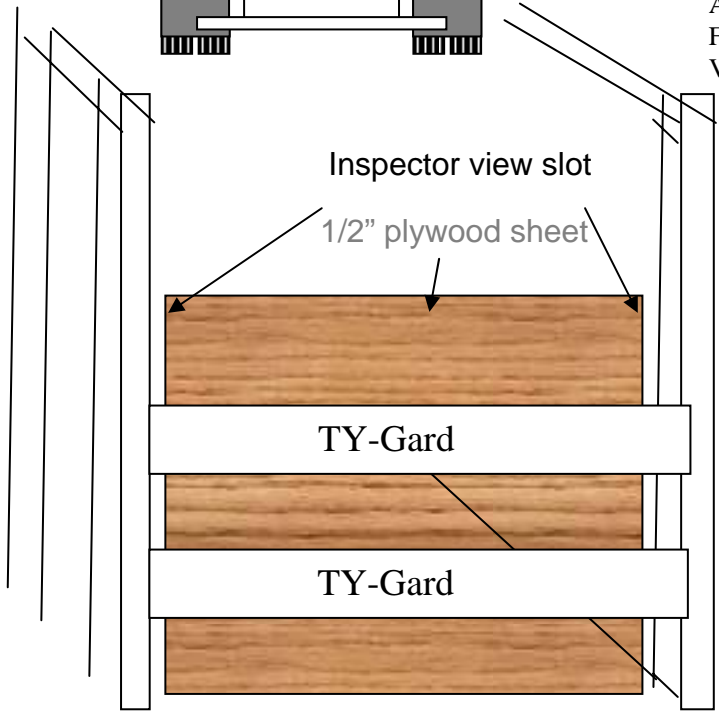
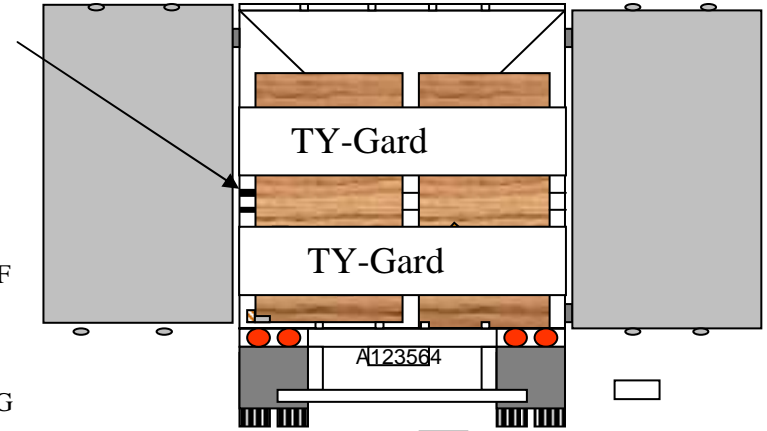

Ty-Gard can be used as a longitudinal restraint.
Rule of Thumb: 1 strip for every 8,800 lb of cargo.
Must glue to side wall , minimum of 5 ft

	Union Pacific Damage Prevention
	File: Ty-gard Installation
	Date: 8/6/03 By:WLR



TYGARD nylon barriers must be glued into wall corrugations – in this load it catches only the ridges of the sidesheet. Barrier will readily pull of wall



Two Tygard barriers taped up to prevent dropping to floor. Sheet of corrugated acts as buffer.



Rear Gate Construction

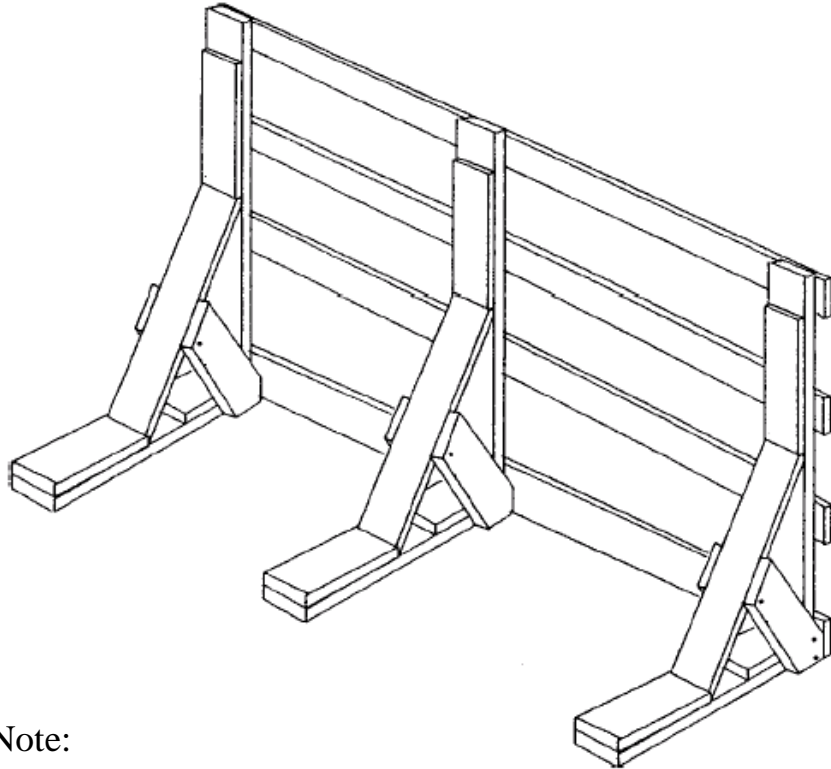

Lengths of Diagonals to Trailer Floor (in feet)

Height of Application of Diagonal Brace to Cross Brace or Load Above Trailer Floor	Minimum Length of Diagonal Brace Required
1	1½
1½	2¼
2	3
2½	3½
3	4¼
3½	5
4	5¾
4½	6½
5	7¼
5½	7¾
6	8½

Note:

- 1) All Material to be 2" x 6" dimensional Lumber
- 2) All Floor Securement Nails to be 16d (3.5")
- 3) All Floor Securement Nails to Applied in a Staggered Nailing Pattern Spaced Every 4-5 inches.



With Knee Brace

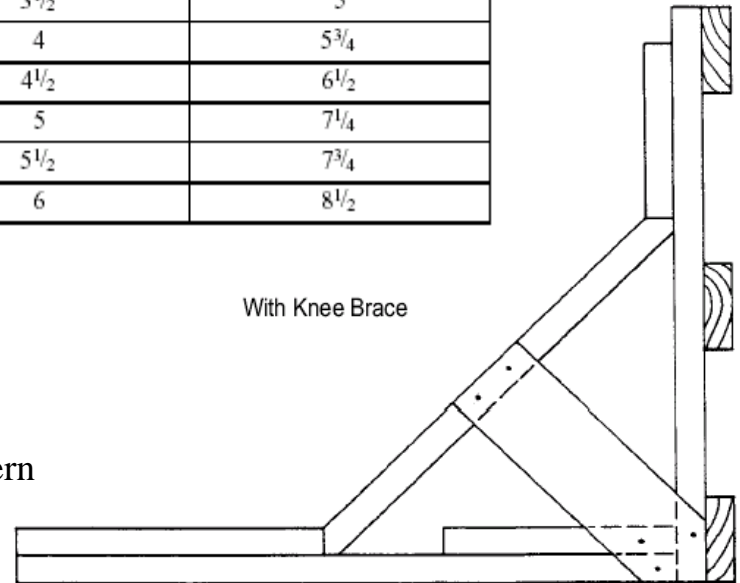



Example of a gate – it should have four braces (two for each pallet behind plywood) and be constructed of quality lumber – not used broken pieces



Second layer blocking should have four verticals with 2" dimension oriented wall to wall .



EMP E-Clips and E-Track Usage

E-Track in EMP equipment extends approximately 6 ft from the doors in 53ft and approx. 3.5 ft in 48 ft equipment.

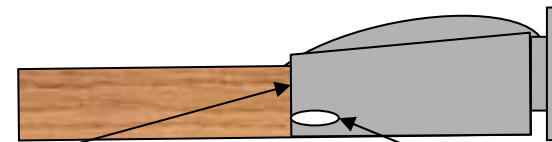
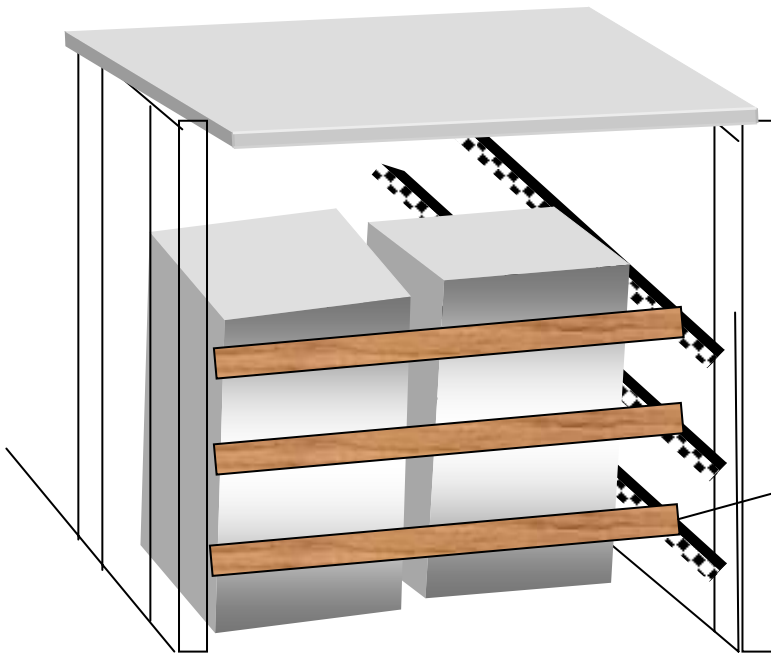

Nail securement hole

2x6 lumber is installed into the track hardware and placed against the cargo to restrain the pallets from any longitudinal movement.

E-clisp are obtainable from
Ancra international
Erlanger, KY 41018
Phone: (800)233-5138
FAX: (800)347-2627

http://www.ancra-llc.com/truck/cat_index.asp

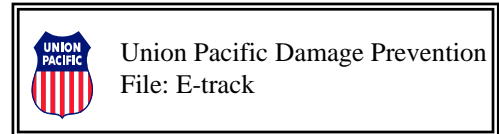

Date: 03/3/03 By: WLR

18 Rolls

45 in Diameter Rolled Paper with Rubber Mats

48ft Containers

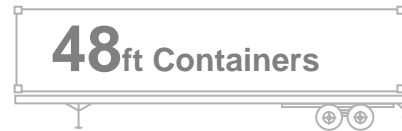

Nose

Side Wall Cutaway View

Rear

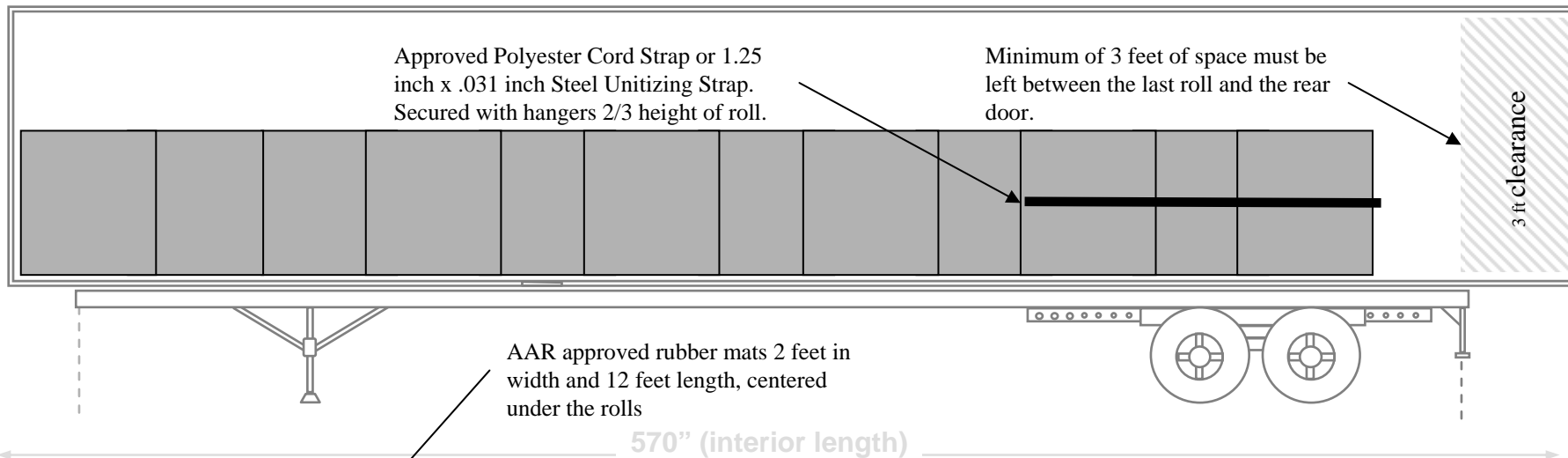

Nose

Overhead View

U= unitized

Rear

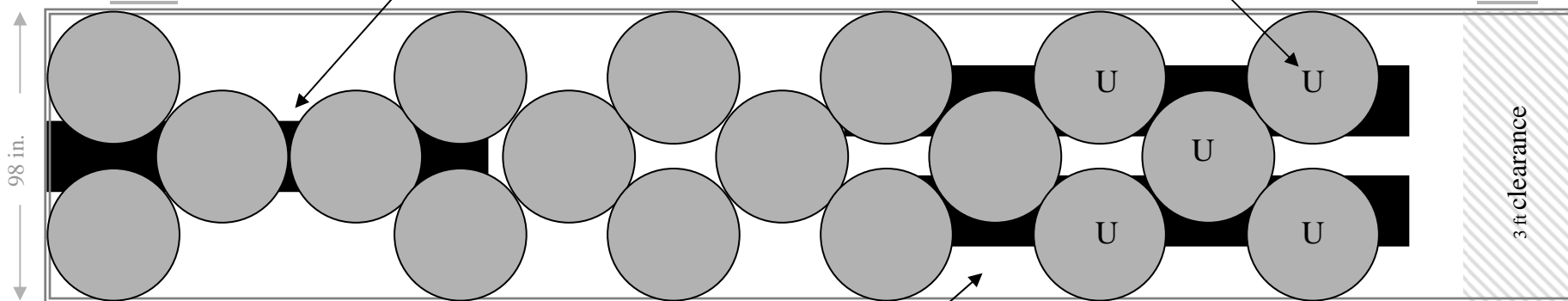

AAR approved rubber mats are to be 2 feet in width and run the length of the rolls. Mats must extend 3 inches beyond the last roll.



Example of a roll unitizing strap (green) –taped up to prevent dropping to floor .This strap is loose and too low. Mats which are required in the absence of floor blocking are not visible . Mats must extend beyond the rolls

Honeycomb Buffer Material

Buffer material

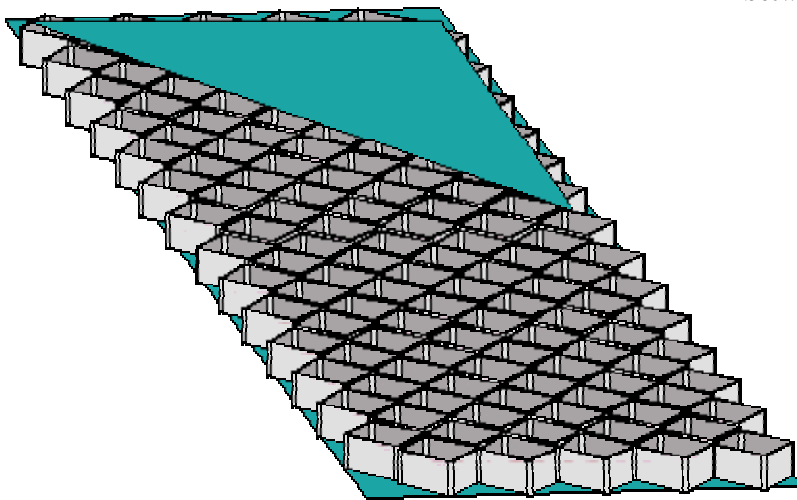

Honeycomb buffer material
between airbag and product

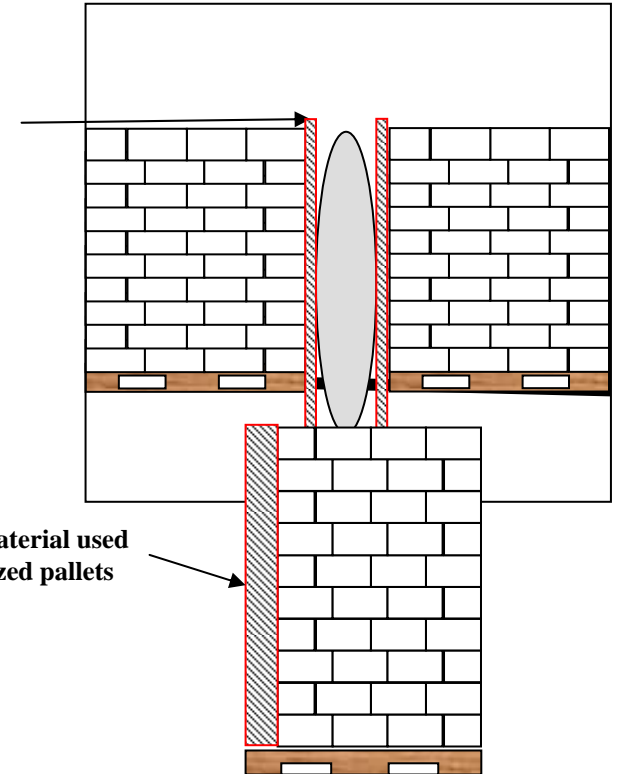

Honeycomb buffer material used
under hand on oversized pallets

Honeycomb Buffer Material Uses :

- 1) Used as buffer material between airbags and products
- 2) Used as void filler to reduce lateral voids in loads
- 3) Can be use to reduce under hang on pallets

This load plan is intended for general information purposes only and is not recommended for any specific cargo. Other Carriers are not required to accept this load plan or any plan suggested by Union Pacific Railroad. This information is offered to shippers to assist in understanding the rail environment, the shipper is ultimately responsible for choosing how best to package, block and brace its cargo to avoid damage to the cargo and rail equipment.



Union Pacific Damage Prevention

File: Buffer material

Date: 06/15/06 By: EOW

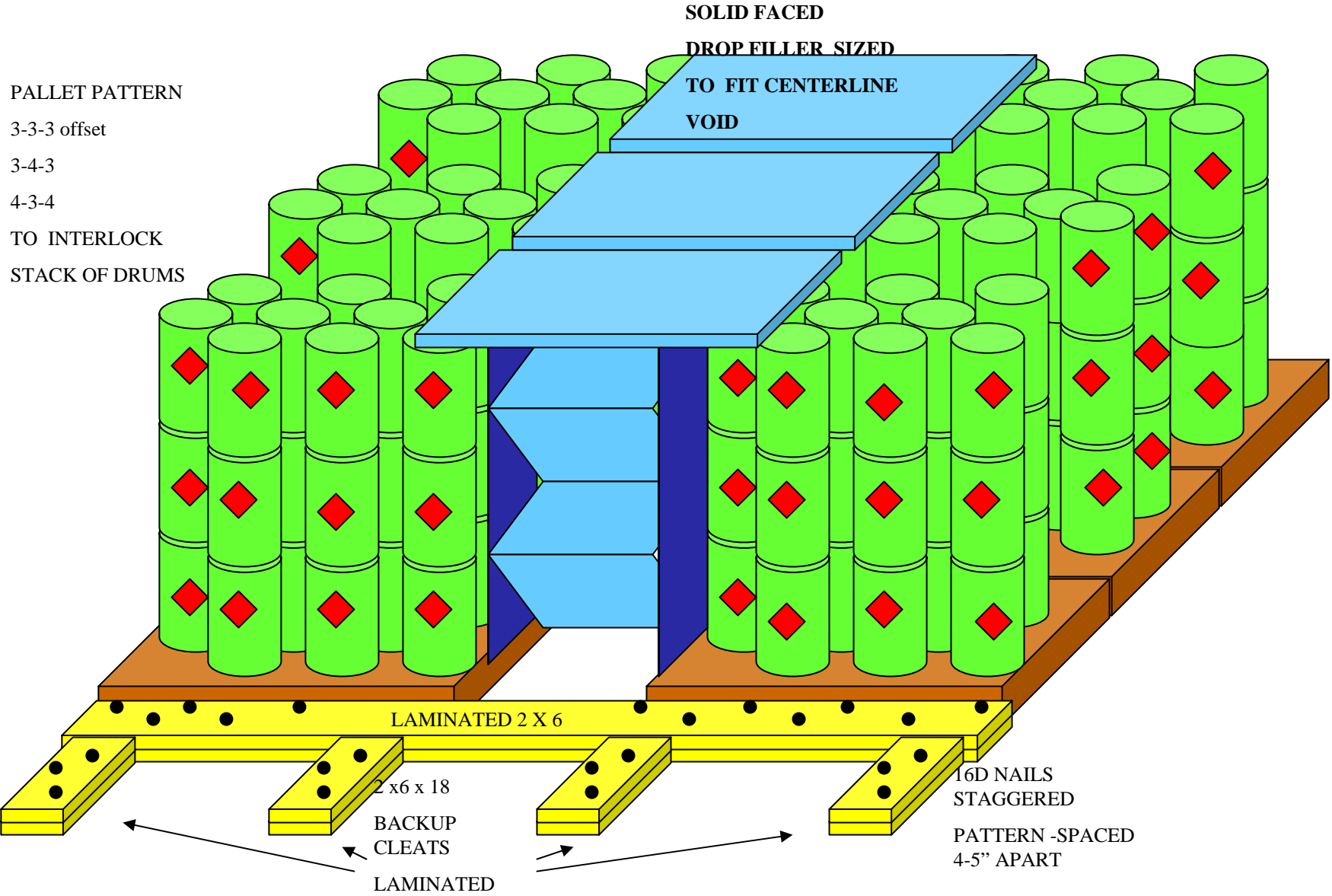



Drop filler would have prevented the lateral shifting h

Recommendation for Stretch Wrap



- Pre-tensioned 150% with four full wraps per stack
- Set top and bottom layer count to four wraps
- 100 gauge stretch wrap, 30" wide
- Adjust roll carrier speed to allow film wrap to overlap the previous applied layer by 15 inches
- Turn-table speed must be adjusted to allow application of 4 top layers

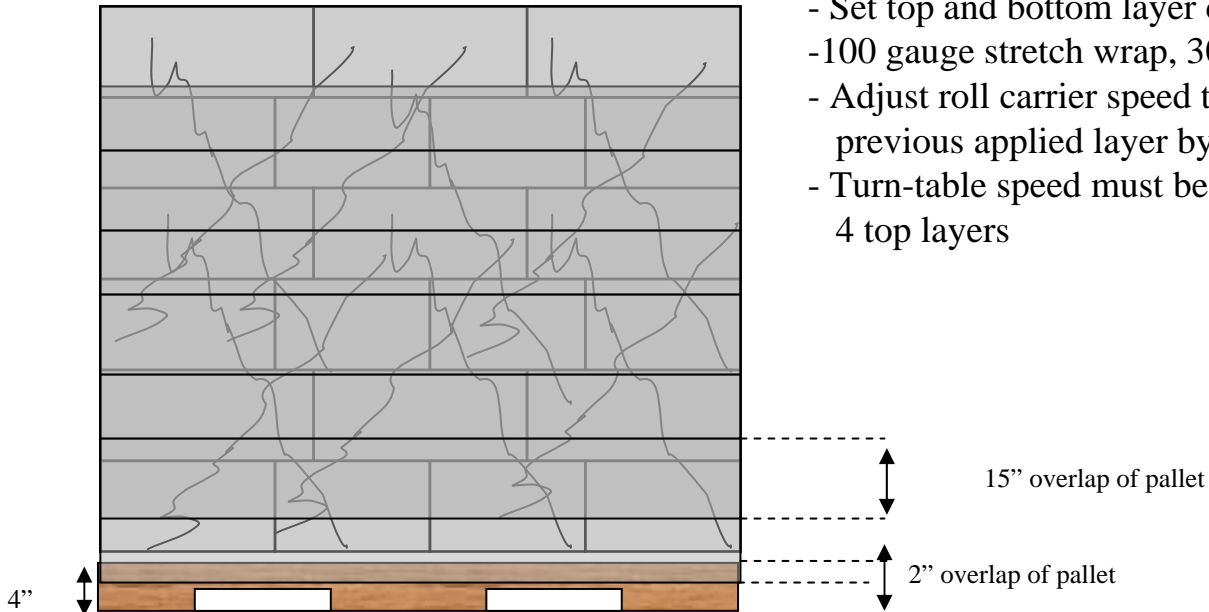

Four full wraps per pallet
with 2" overlap to the pallet and top of the load

This load plan is intended for general information purposes only and is not recommended for any specific cargo. Other Carriers are not required to accept this load plan or any plan suggested by Union Pacific Railroad. This information is offered to shippers to assist in understanding the rail environment, the shipper is ultimately responsible for choosing how best to package, block and brace its cargo to avoid damage to the cargo and rail equipment.

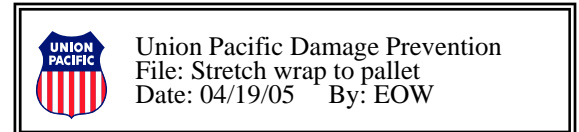



Drop filler positioned between pails is acceptable lateral filler. 2x4's in black plastic Logistick brackets are not approved as applied. Load needs to be broken into three sections, with three logistics and floor blocking at each section. 2x4's need to be faced with plywood , osb or diamond cor to prevent imprinting pails

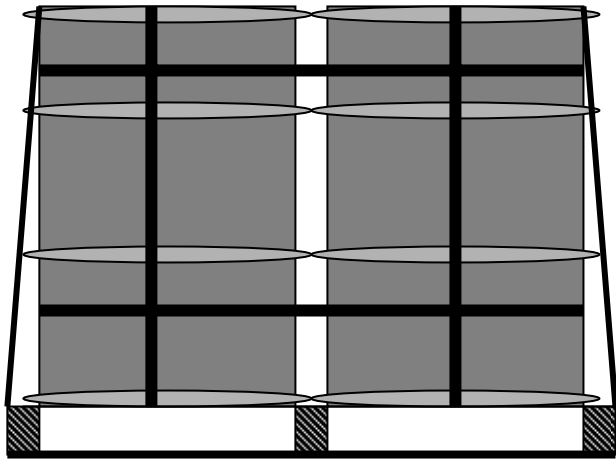

DRUMS ON PALLETS

DRUMS MUST BE UNITIZED
TOGETHER AND EACH ROW
MUST BE BANDED TO THE
PALLET LONGITUDINALLY AND
LATERALLY WITH MINIMUM 1.25"
BANDING